

Outils de serrage et de manutention  
*Einspannungswerkzeuge*  
Gripping and handling tools

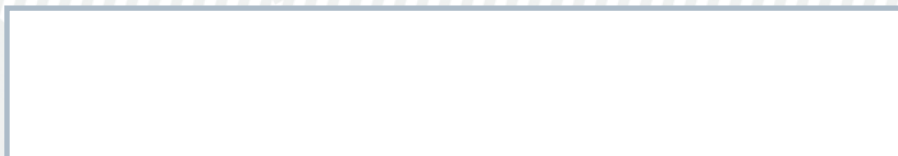
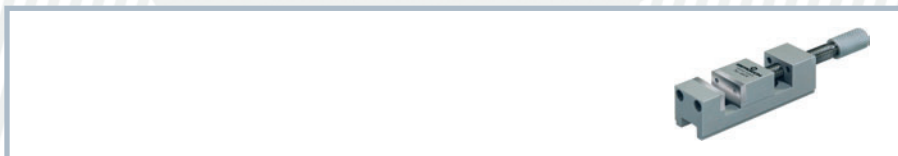

Assortiment de 5 mandrins. Première qualité  
Tête ronde

*Sortiment von 5 Stiftenklöbchen. Erste Qualität  
Runder Kopf*

Assortment of 5 pin vices. First quality  
Round head

**30026-A**  2001



4

Mandrins

*Stiftenklöben*

Pin vices

L: 80 mm / 0-0.70 mm

**30021-1**  2001



L: 90 mm / 0-1.00 / 1.00-1.50 mm

**30022-2**  2001



L: 100 mm / 1.00-1.50 / 1.50-2.00 mm

**30023-3**  2001



L: 120 mm / 2.00-2.50 / 2.50-3.00 mm

**30024-4**  2001



L: 130 mm / 3.00-3.50 / 3.50-4.00 mm

**30025-5**  2001



Assortiment de 3 mandrins. No. 1-2-3

*Sortiment von 3 Stiftenklöbchen. No. 1-2-3*

Assortment of 3 pin vices. No. 1-2-3

**30026-D**  2002



4



Assortiment de 4 mandrins  
*Sortiment von 4 Stiftenklöbchen*  
Assortment of 4 pin vices

**1842-A**  2002

**1842-B**  2002



Mandrins  
*Stiftenklöben*

Pin vices

| L   |  | No              |
|-----|---|-----------------|
| 80  | 0-1.0 0.8-2.0   | <b>1842-18A</b> |
| 100 | 0-1.2 1.5-3.0   | <b>1842-17A</b> |
| 120 | 0-1.5 2.5-4.0   | <b>1842-16A</b> |
| 140 | 0-1.5 4.0-5.0   | <b>1842-15A</b> |

**1842-...A**  2002



**1842-...B**  2002

| L   |  | No              |
|-----|---|-----------------|
| 80  | 0-1.0 0.8-2.0   | <b>1842-18B</b> |
| 100 | 0-1.2 1.5-3.0   | <b>1842-17B</b> |
| 120 | 0-1.5 2.5-4.0   | <b>1842-16B</b> |
| 140 | 0-1.5 4.0-5.0   | <b>1842-15B</b> |



Assortiment de 3 mandrins. Manche en laiton  
*Sortiment von 3 Stiftenklöbchen. Messinggriff*  
Assortment of 3 pin vices. Brass handle

**1839-A**  2003



**1839-11** L: 80 / 0-0.8 mm  2003



**1839-10** L: 100 / 0-1.2 mm  2003



**1839-09** L: 120 / 1.4-2.5 mm  2003

Assortiment de 3 mandrins. Manche bois cannelé  
*Sortiment von 3 Stiftenklöbchen. Heft kanneliertes Holz*  
Assortment of 3 pin vices. Handle grooved wood

**1838-A**

 2003



4

**1838-8**

L: 80 / 0-0.8 mm

 2003



**1838-7**

L: 100 / 0-1.0 mm

 2003



**1838-6**

L: 120 / 0-1.2 mm

 2003



Mandrins avec 2 pinces  
*Stiftenklöbchen mit 2 Zangen*

Pin vices with 2 chucks

0-1.2/2.3-3 mm

**1841**

L: 110 mm

 2004



0-1.5/1.9-3 mm

**5679**

L: 115 mm

 2004



0-1.3/1.7-3 mm

**5678**

L: 115 mm

 2004



Mandrin avec 2 pinces réversibles  
*Stiftenklöbchen mit 2 umkehrbaren Zangen*

Pin vice with 2 reversible chucks

0-1.7/2.5-3.2 mm

**5860**

L: 108 mm

 2004



Mandrin porte-équarisseur

*Reibahlenhalter*

Pin vice reamer holder

**1845**

L: 60 mm / 0-1.2 mm

 2004



4



Mandrin pour taraud  
*Gewindebohrerhalter*

Tap holder

**2274-A** L: 62 mm / 1.8-3 mm  2004



**2274-B** L: 54 mm / 0.8-1.5 mm  2004



Mandrin porte-équarisseur

*Reibahlenhalter*

Pin vice reamer holder

**4719** L: 40 mm / 0-1 mm  2004



Mandrin à coulant pour tenir les fourchettes

*Stiftenklöbchen zum Halten der Ankergabeln*

Pallet fork holder

**30433** L: 100 mm  2005



Mandrin aux vis de balanciers

*Stiftenklöbchen für Unruhsschrauben*

Holders for balance screws

 0.20 > 1.00 mm

**2567-...** L: 100 mm  2005



Assortiment de 8 mandrins

*Sortiment von 8 Stiftenklöbchen*

Assortment of 8 holders

**2565** Ø 0.25 > 0.70 mm  2005

Assortiment de 3 mandrins

*Sortiment von 3 Stiftenklöbchen*

Assortment of 3 holders

**2566**

Ø 0.30 > 0.50 mm

 2005



4

Mandrin pour ressorts "Circlip"

*Halter für "Circlip" Spaltenfeder*

Holder for "Circlip" springs

**6714**

L: 115 mm

 2006



Mandrin pour tenir les spiraux

*Schiebezange zum Halten der Spiralen*

Pin vice for holding hairsprings

**4072**

L: 105 mm

 2006



Mandrin à coulant pour tenir les arbres de barillet

*Schiebezange zum Halten der Federkerne*

Barrel arbor holder, slide locking jaws

Ø 0.75 > 2.50 mm

**30610-...**

L: 120 mm

 2006



Mandrin de serrage à coulant

*Stiftenklöbchen mit Schieber zum Festellen*

Holder with slide locking steel jaws

**30432**

L: 110 mm / 0-1.5 mm

 2006



Mandrin-fraise à ébaver. Avec 4 dents

*Fräser in Stiftenklöbchenform zum Entgraten.*

*Mit 4 Zähnen*

Burr remover. With 4 teeth

**30511**

L: 110 mm

 2007



4



Manches de burins avec 2 pinces mandrin

*Stichelhefte mit 2 Stiftenklöbchenzangen*

Graver handles with 2 chucks

**1843-19** Ø 35 mm  2008

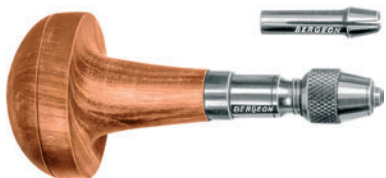

Manches de burins avec 2 pinces mandrin

*Stichelhefte mit 2 Stiftenklöbchenzangen*

Graver handles with 2 chucks

**1843-20** Ø 35 mm  2008



Coeurs entraîneurs

*Drehherze*

Carriers

**30218-...** No 0 > 10  2008



Etau d'établi amovible pour horloger.

Largeur des mâchoires 45 mm

*Werkischabnehmbare Uhrmacher-Schraubstock.  
Backenbreite 45 mm*

Bench removable vice for watchmakers.

Width of jaws 45 mm

**2021**  2035



Plaque seule

*Platte allein*

Plate only

**2021-A**  2035



Etau d'établi fixe. Largeur des mâchoires 45 mm

*Werkischfester Schraubstock.. Backenbreite 45 mm*

Bench fixed vice. Width of jaws 45 mm

**5008**  2035

Etau à pattes

*Bankschraubstock*

Bench-vices

A: 225 x B: 60 mm x C: 158 mm D: 60 mm

**4573-60**

 2036

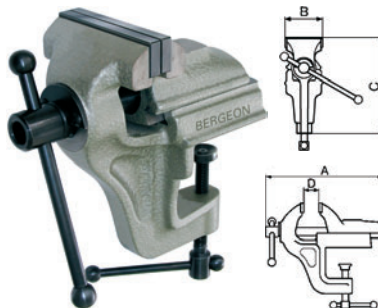

4

Etau mobile avec serrage à rotule

Largeur des mâchoires 50 mm

*Kugelgelenk-Aufspannung Spannbacken*

*Backenbreite 50 mm*

Movable vice with gripping bearing ball

Width of jaws 50 mm

**5293**

Cap.: 0 - 70 mm

 2036



Etau ventouse, mobile avec serrage à rotule

Largeur des mâchoires 75 mm

*Vakuumschraubstock, beweglich mit Kugelgelenk*

*Backenbreite 75 mm*

Vacuum-vice, movable with bearing-ball

Width of jaws 75 mm

**6691**

Cap.: 0 - 40 mm

 2037



Etau à main

*Handfeilkloben*

Hand-vice

**1799-08**

L: 115 mm - 8 mm

 2037

**1799-15**

L: 115 mm - 15 mm

 2037



Bois d'étau en buis

*Steckholz aus Buchsbaum*

Boxwood chops for vice

**1588**

 2038

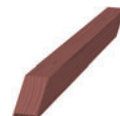

4

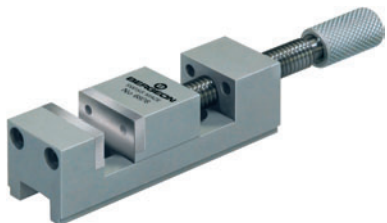

Etau de précision  
*Präzisionschraubstock*  
Precision vice

Cap.: 0 - 15 mm

**6876** 15 x 15 x 76 mm  2039



Jeu de 2 plaquettes. En acier trempé rectifié  
*Satz von 2 Plättchen. Aus gehärtetem, rektifiziertem Stahl*  
Set of 2 plates. Hardened, rectified steel

**6876-P**  2039



Support orientable  
*Verstellbarer Halter*  
Adjustable support

**6876-S** Ø 50 x 37 mm  2039