

Outils et accessoires pour les bracelets
*Werkzeuge und Zubehör
für Armbänder*
Tools and accessories for bracelets

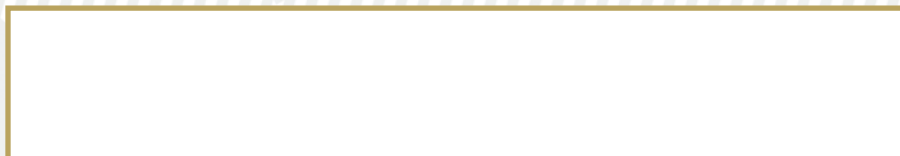

Moteur à scier les anses de bracelets. Largeur max. de coupe 30 mm. Meule: Ø 65 mm

Motor zum Schneiden der Armbandglieder. Max. Schnittbreite: 30 mm. Schleifscheibe: Ø 65 mm

Motor for sawing bracelet lugs

Dim. 180 x 125 x 125 mm

5683-110 110 V

 7007-A

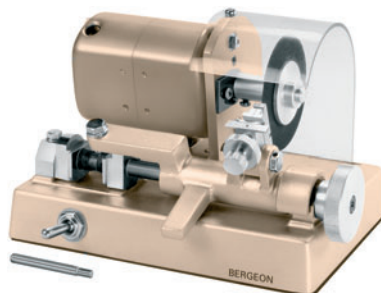

5683-220 220 V

 7007-A

Meule de rechange

Ersatzschleifscheibe

Spare wheel

Ø 0.5 mm

5544-C-... Ø 65 mm

 7007-A



Etau à main pour visser et dévisser les bracelets.
Etau seul. Mèche Ø 1.80 mm. Pour visser et dévisser de la carrure, les barrettes à vis des bracelets de toutes épaisseurs ainsi que les maillons de bracelets.

Coussins de rechange. Haut ou bas

Rollenbänder-Halter. Halter allein. Klinge Ø 1.80 mm. Zum Schrauben und Entschrauben der Armbandstifte. Ersatzkissen. Oben oder unten

Hand vice for screwing and unscrewing bracelets.
Hand vice alone. Blade Ø 1.80 mm. To screw and unscrew bars of bracelets and links of any thickness.
Spare cushions. Upper or lower

6670

 7007-C



12

Coussins de rechange. Haut ou bas

Ersatzkissen. Oben oder unten

Spare cushions. Upper or lower

6670-DB **6670-DH**

 7007-C

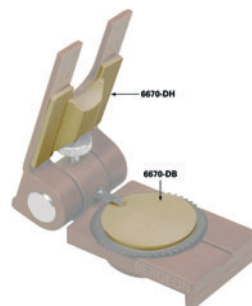



Etau complet. Comprenant: 1 socle bois:
120 x 80 x 15 mm. 1 tournevis, mèche Ø 1.40 mm.
4 mèches Ø 1.00 - 1.40 - 1.80 - 3.00 mm

*Halter Komplett. Halter Komplett Satz mit: 1 Holzsockel:
120 x 80 x 15 mm. 1 Schraubenzieher, Klinge
Ø 1.40 mm. 4 Klingen Ø 1.00 - 1.40 - 1.80 - 3.00 mm*

Complete hand vice. Including: 1 wooden stand:
120 x 80 x 15 mm. 1 screwdriver, blade Ø 1.40 mm.
4 blades Ø 1.00 - 1.40 - 1.80 - 3.00 mm

6670-S

7007-C

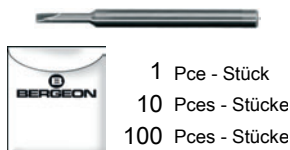

1 Pce - Stück
10 Pces - Stücke
100 Pces - Stücke

Mèches de recharge

Ersatzklinge

Spare blades

Ø 1.00 - 1.40 - 1.80 - 3.00 mm

6670-M-...

7007-C



Socle pour dévisser et visser les bracelets.

Base Ø 70 mm. Avec 4 mèches de tournevis Ø 1.00 -
1.40 - 1.80 - 3.00 mm

*Sockel zum Schrauben und Entschrauben der
Armbänder. Basis Ø 70 mm. Mit 4
Schraubenzieherklingen Ø 1.00 - 1.40 - 1.80 - 3.00 mm*

Base to unscrew and screw bracelets. Base Ø 70 mm.
With 4 screwdriver blades Ø 1.00 - 1.40 - 1.80 - 3.00 mm

6730

7007-D

Outil à déchasser les goupilles des bracelets métalliques.

Tête à ressort. Goupille de recharge

Werkzeug zum Ausstossen der Metallarmbandstifte.

Ersatzklinge. Ersatz Strift

Tool for removing pins of metal bracelet. Spare blades.

Spare pins

6156

54 x 44 x 19 mm

7007-D



Pince pour enlever et poser les boutons à pression de bracelets. En fonte aluminium. Spatules interchangeables. Spatule de rechange

Zange zum Entfernen und Setzen des Druckknöpfe der armbänder. Aus Aluminium-Guss. Auswechselbare Spachteln. Ersatz-Spachteln

Pliers to remove and fit pressure type springbars from bracelets. Aluminium casting. Interchangeable blades. Spare blade

6618

L: 160 mm

 7007-E

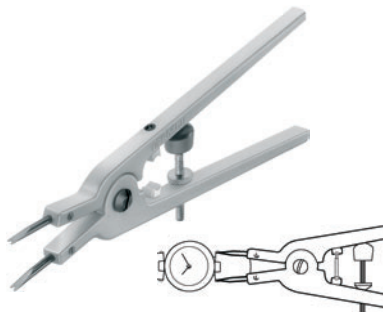

Outil pour déchasser et chasser les goupilles de bracelets

Werkzeug zum Ausschlagen und Einsetzen der Armbandstifte

Tool to drive bracelet pins in and out

6578

 7007-F

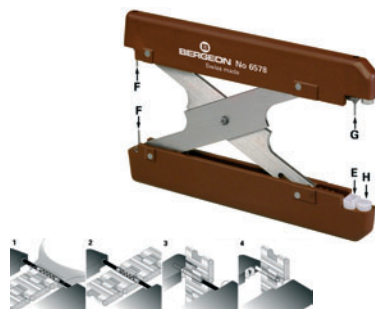

Tasseau nylon

Nylon-Einsatz

Nylon stake

6578-E

 7007-F



Tasseau nylon

Nylon-Einsatz

Nylon stake

6578-H

 7007-F



Goupille

Stifte

Broach

Ø 0.70 - 0.80 - 0.90 - 1.15 mm

6578-G...

 7007-F



12

Outil pour poser et enlever les barrettes à ressorts. En bakélite
Werkzeug zum Setzen und Entfernen der Federösen. Aus Bakelit
 Tool for fitting and removing spring-bars. Bakelite handle

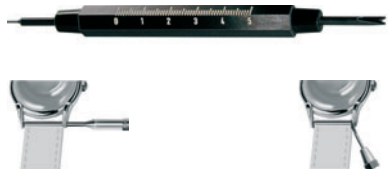

Avec pointe et fourchette standard
Mit Standard Spitzen und Gabeln
 With standard points and forks

3153 L: 148 mm

7007-G



Pointes de rechange
Ersatzspitzen
 Spare points

3153-B **3153-A** 7007-G



Outil avec pointe et fourchette standard. Manche en laiton poli nickelé
Werkzeug mit Standard Spitzen und Gabeln. Messinggriff glanzvernickelt

Tool with standard points and forks. Handle in polish nickel-plated brass

6767-S L: 145 mm

7007-G



Pointes de rechange en acier trempé revenu
Ersatzspitzen in gehärtetem Stahl
 Spare points in hardened tempering steel

6767-A **6767-B** 7007-G



Avec pointe et fourchette fine. Pointes en acier trempé revenu
Mit feinen Spitzen und Gabeln. Spitzen in gehärtetem Stahl

With fine points and forks. Points in hardened tempering steel

6767-F L: 145 mm

7007-H



Pointes de rechange en acier trempé revenu
Ersatzspitzen in gehärtetem Stahl
 Spare points in hardened tempering steel

6767-BF **6767-AF** 7007-H

Outil avec pointe réversible et fourchette en forme de spatule. Manche nickelé et moleté. Serrage par mandrin

Werkzeug mit umkehrbarer Spitze und Gabel in Spachtelform. Gerändelter Griff vernickelt. Festschrauben mit Spannfutter

Tool with reversible point and spatula-shaped fork. Nickel-plated and knurled handle. Gripping with chuck





6111 L: 140 mm  7007-H

Pointes de recharge

Ersatzspitzen

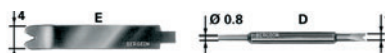
Spare points



6111-D **6111-E**  7007-H

Pince pour poser les bracelets de montres munis de barettes à ressort. Fabrication soignée en aluminium anodisé

Zange zum Einsetzen der Uhren-Armbänder mit Federstegen. Gepflegte Ausführung in anodisiertem Aluminium

Plier to fit wristwatches' bracelets provided with spring-bars. Fine quality aluminium casting. Very easy to handle

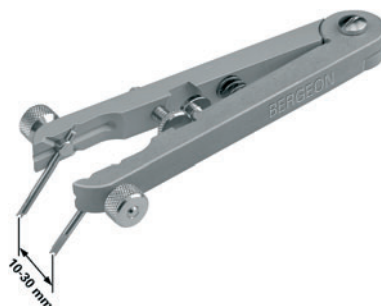

6825 L: 95 mm  7007-I 

12

Fourche de recharge réversible

Ersatzgabel umkehrbare

Reversible spare fork

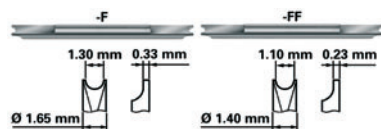

6825-F **6825-FF**  7007-I

Assortiment de 5 chasse-goupilles. Manche en acier inox, garni d'une membrane en élastomère.

Livré avec 3 goupilles de recharge en tube

Sortiment von 5 Stift-Austreiber. Heft rostfreier Stahl, überzogen mit eine Elastomer-Membran. Geliefert mit 3 Ersatz-Stiften in einer Tube

Assortment of 5 pin-extractors. Stainless steel handle with an elastomer membrane.

Comes with 3 exchange pins in tube

Ø 0.70 - 0.80 - 0.90 - 1.00 - 1.20 mm



6988  7007-J



Chasse-goupilles

Stift-Austreiber

Pin extractors

Ø 0.70 - 0.80 - 0.90 - 1.00 - 1.20 mm

6988-070 > 6988-120

7007-J



Goupilles à déchasser

Ausstosstifte

Pins

Ø 0.70 - 0.80 - 0.90 - 1.00 - 1.20 mm

6988-G-070 >

7007-J

6988-G-120



Potence multi-usages. Pour chasser et déchasser les goupilles, visser et dévisser les vis des bracelets de montres

Presstock zum vielseitigen Gebrauch. Zum Ein- und Ausschlagen der Stifte, Schrauben- und Entschrauben der Uhrarmbandschrauben

Press for multi-uses. To drive in and out pins, to screw and unscrew watch-bracelets

6745-100

7007-K



12



Potence pour déchasser les goupilles de bracelets

Presstock zum Ausstossen der Armbandstifte

Press to drive out bracelets pins

6745

6745-PS

7007-L

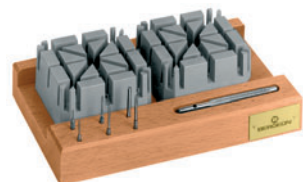

Outillages pour déchasser les goupilles de bracelets

Rollenbandkürzer-Sätze

Toolings to drive out bracelet pins

6744

140 x 87 x 20 mm

7007-L



Posage pour bracelets

Untersatz für Uhrenbänder

Bracelets-support

6744-P

53 x 53 x 26 mm



7007-M



Pour bracelets épais

Für dicke Armbänder

For thick bracelets

6744-1



7007-M



Posages pour bracelets

Untersatz für Uhrenbänder

Bracelets-supports

6744-P1

53 x 53 x 26 mm



7007-M



Posages pour bracelets. En matière synthétique "SOFT".
Utilisés spécialement pour tous les métaux précieux sans
aucun risque de rayures

*Untersatz für Uhrenbänder. Aus synthetischem Material
"Soft". Besonders geeignet für Edelmetalle, kein
Kratzrisiko*

Bracelets-supports. In « SOFT » synthetic material.

Especially made for all precious metals, without any risk
of scratches

53 x 53 x 26 mm

6744-P1-S

6744-P-S



7007-Q

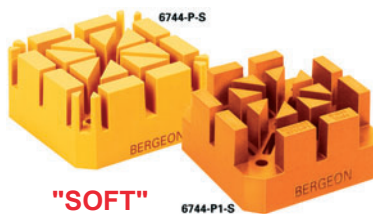

"SOFT"

6744-P1-S

12

Goupilles à déchasser. En pochettes de 1000 pces,
100 pces, 10 pces, ou 1 pce

*Ausstosstifte. In Falten zu 1000 Stück, 100 Stück,
10 Stück oder 1 Stück*

Pins to drive out. In bags of 1000 pces, 100 pces, 10 pces
or 1 pce

Ø 0.40 - 0.60 - 0.70 - 0.80 - 0.90 - 1.00 - 1.20 1.50 - 2.00 mm

6745-G-...



7007-M





Mèches droites. En pochettes de 100 pces, 10 pces ou 1 pce

Gerade Klingen. In Falten zu 100 Stück, 10 Stück oder 1 Stück

Straight blades. In bags of 100 pces, 10 pces or 1 pce
Ø 0.80 - 1.00 - 1.50 - 2.00 mm

6745-M-...  7007-N



Mèches cruciformes. En pochettes de 100 pces, 10 pces ou 1 pce

Kreuzschlitz- Klingen. In Falten zu 100 Stück, 10 Stück oder 1 Stück

Cruciforme blades. In bags of 100 pces, 10 pces or 1 pce

6745-MC-... Ø 1.50 - 2.00 mm  7007-N



Assortiment de 6 goupilles

Sortiment von 6 Stiften

Assortment of 10 blades

Ø 0.40 - 0.60 - 0.80 - 1.00 - 1.50 - 2.00 mm

6745-GS  7007-N

12



Assortiment de 10 mèches.

Sortiment von 10 Klingen.

Assortment of 10 blades.

⊕ 2x Ø 0.80 - 2x 1.00 - 2x 1.20 - 1x 1.50 - 1x 2.00 mm

6745-MS  7007-N



Porte-goupille avec tambour. Corps Ø 4.7 mm

Stiftenhalter mit Trommel. Shaft Ø 4.7 mm

Pin holder with drum. Shank Ø 4.7 mm

6745-PG-A  7007-N



Porte-goupille. S'utilise avec la potence No 6745 et l'outillage No 6744 ainsi qu'avec les potences à river No 5285

Tragen-Stift. Wird mit dem Presstock Nr. 6745, und Werkzeug Nr. 6744, sowie den Triebnietmaschinen Nr. 5285 benutzt

Carry-pin. To be used with press No 6745 and tooling No 6744, as well as staking-tools No 5285

6745-PG L: 80 mm / Ø 4.7 mm  7007-O

Porte-goupille. Manche cannelé. S'utilise avec l'outillage
No 6744

*Stifthalter. Geriffeltes Heft. Wird mit und Werkzeug
Nr. 6744 benutzt*

Pin holder. Knurled handle. To be used with tooling
No 6744

6744-PG L: 60 mm  7007-O



Bases à hauteur variable

Auflage mit regulierbarer Höhe

Adjustable height bases

H: 14 > 19 mm

6745-SR20 Ø 20 mm  7007-O

6745-SR28 Ø 28 mm  7007-O



Tasseaux supérieurs

Upper holders

Obere Halter

6745-SR20-A Ø 20 mm  7007-O

6745-SR28-A Ø 28 mm  7007-O



Tasseau de base fendu, en acier

Einsatz mit gespaltenem Sockel, aus stahl

Cracked base chuck, in steel

6745-DF Int. Ø 2 mm  7007-O



Accessoires complémentaires

pour adapter la potence 6745 en potence 6745-100

Ergänzungssatz

für Presstock 6745 in Presstock 6745-100 umzuwandeln

Complemental accessories

to adapt the press 6745 into a press 6745-100

6745-ASS  7007-P 





Chasse-goupilles. Avec 6 pointes

Stift-Austreiber. Mit 6 Stiften

Pin extractors. With 6 points

No 6745-G: Ø 0.40 - 0.60 - 0.80 - 1.00 - 1.50 - 2.00 mm

1616

 7007-Q



Pince pour enlever et poser les goupilles de bracelets métalliques

Zange zum Ausstossen und Einsetzen der Stifte von Metallarmbändern

Pliers to drive out and to remove pins for all types of metal bands

6819

 7007-R



Poussoirs à déchasser. Pièces de rechange

Stößel zum Ausstossen. Ersatzteile

Plunger. Spare-parts

6819-1...

 7007-S

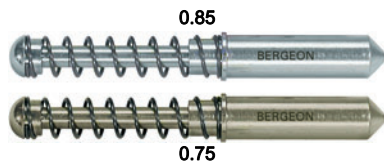

Goupilles de rechange

Ersatzstifte

Pins of replacement

6819-1-G...

 7007-S

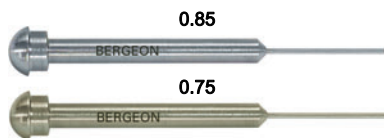

Poussoir à chasser

Einsetzstößel

Insertion plunger

6819-2

 7007-S



Cales

Keil

Block

No **1** (11 mm), No **2** (8 mm),
No **3** (5 mm), No **4** (5 - 4 mm)

6819-3...

 7007-S

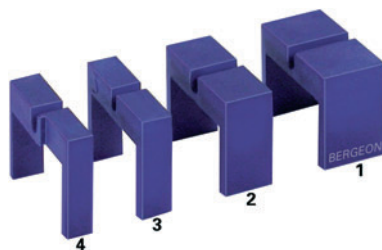



Pince pour découper les bracelets en cuir. En laiton sablée chromé

Zange zum Schneiden der Leder-Armbänder. Aus Messing, sandgestrahlt, verchromt

Pliers to cut shapes into leather straps. In brass, sanded and chromuimplated

Dim. mm		Dim. mm	
	2		2
	4		4
	6		6
	6620-D		6620-G
	6620-E		6620-H
	6620-F		6620-J
	6620-K		

6620

L: 160 mm

8039

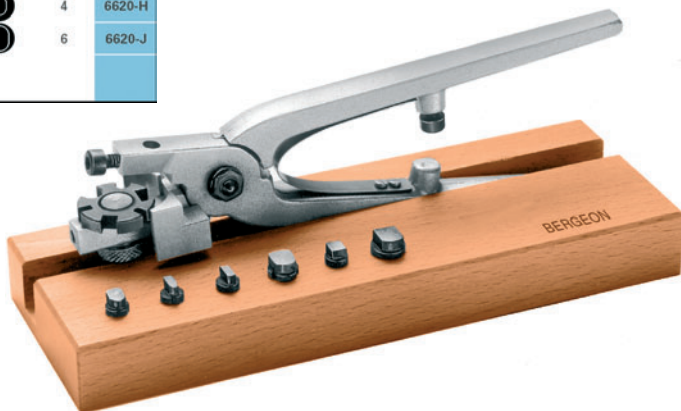

Pince à découper les bracelets pour barettes à ergots.
Cette pince a été développée spécialement pour monter
les barettes à ergot à un bracelet standard

*Bänderlochzange mit Riegelstiften. Diese Zange wurde
speziell entwickelt, um die praktischen
Wechsel-federaschen an Standard-Lederarmbänder
montieren zu können*

Cutting plier for straps to fix catches spring bars. This plier
has been developed especially to fit spring bars with lever
on a normal bracelet

30227

 8040



12